

# TALL CABINET BODY

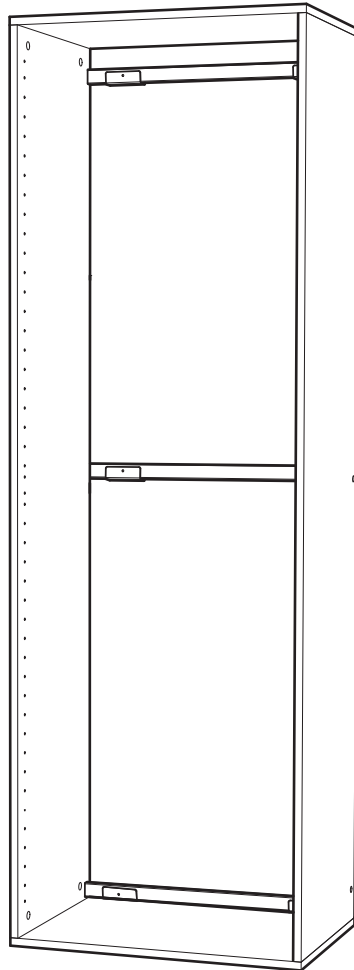

Model: **FWC-CAB1.2**



---



1891 W 2100 S  
Salt Lake City, UT 84119  
(877)-203-5974  
customerservice@flowwall.com

# PARTS LIST

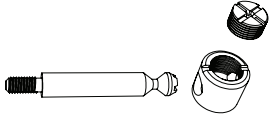
TALL CABINET BODY FWC-CAB1.2

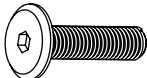
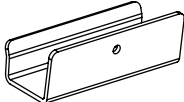
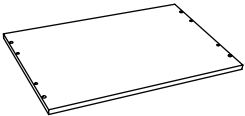
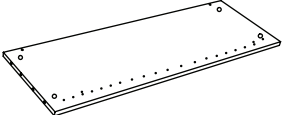
NO.	PICTURE	PART DESCRIPTION	QTY.
A	 A technical drawing of a cam post, showing a long cylindrical shaft with a hexagonal base and a cam-shaped end. Two views are shown: a side view and a top-down view of the cam end.	Cam Post	8
B	 A technical drawing of a simple cylindrical dowel pin.	Dowel	8
C	 A technical drawing of a long, thin, rectangular steel spanner.	Steel Spanner	3
D	 A technical drawing of a spanner screw, which is a screw with a hexagonal head and a threaded shaft.	Spanner Screw	6
E	 A technical drawing of a spanner bracket, which is a U-shaped metal piece with a hole in the center.	Spanner Bracket	6
F	 A technical drawing of a rectangular panel, likely the top or bottom panel of the cabinet, showing a series of small holes along the edges.	Top/Bottom	2
G	 A technical drawing of a rectangular side panel, showing a series of small holes along the edges.	Side Panel	2

**Step 1.**

**Mount Posts** - Screw cam posts (A) into receiver holes on top & bottom panels (F).

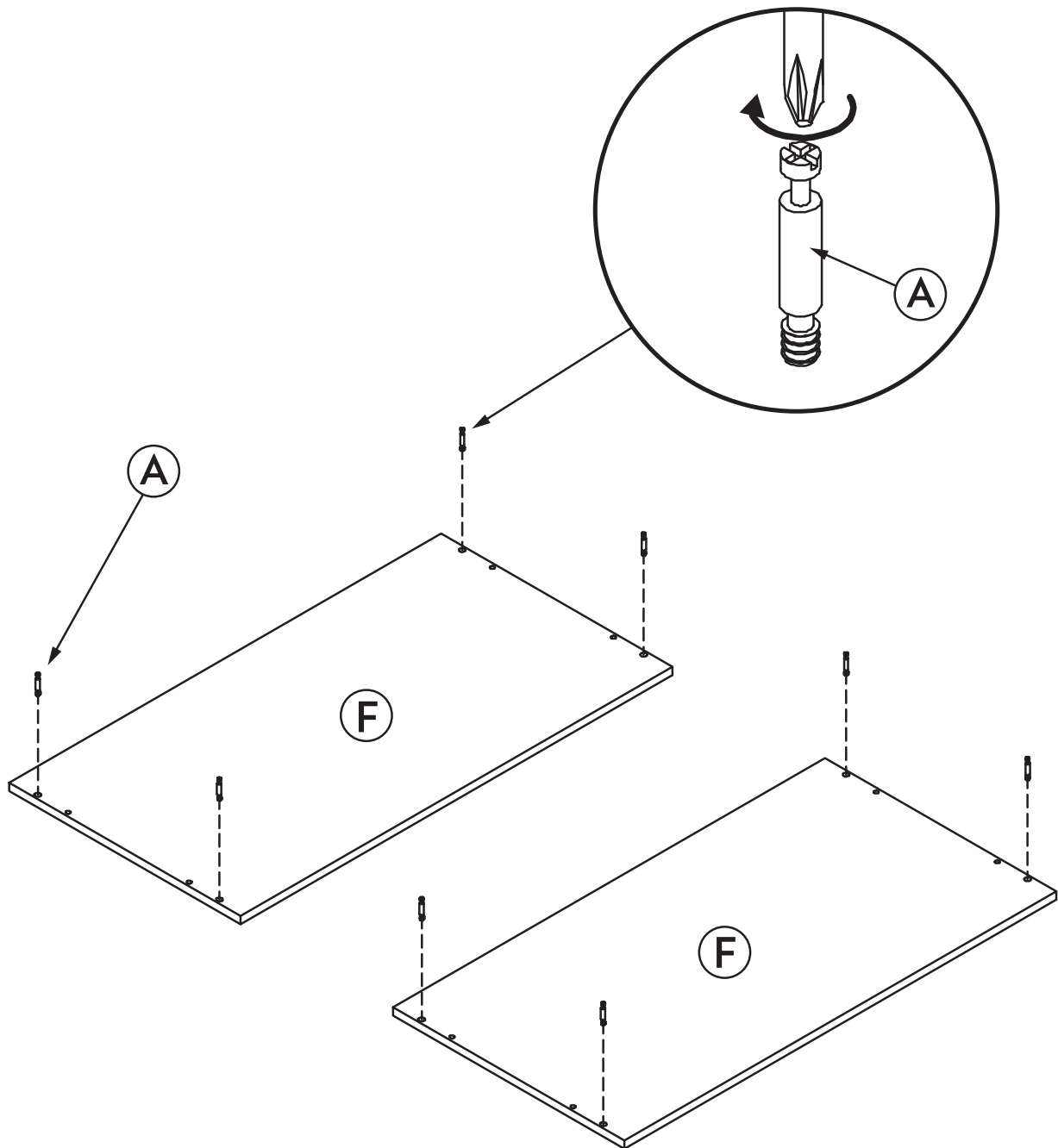

**Step 2.**

Side Panel - Glue and insert dowels (B) into side panels (G). (Glue optional)

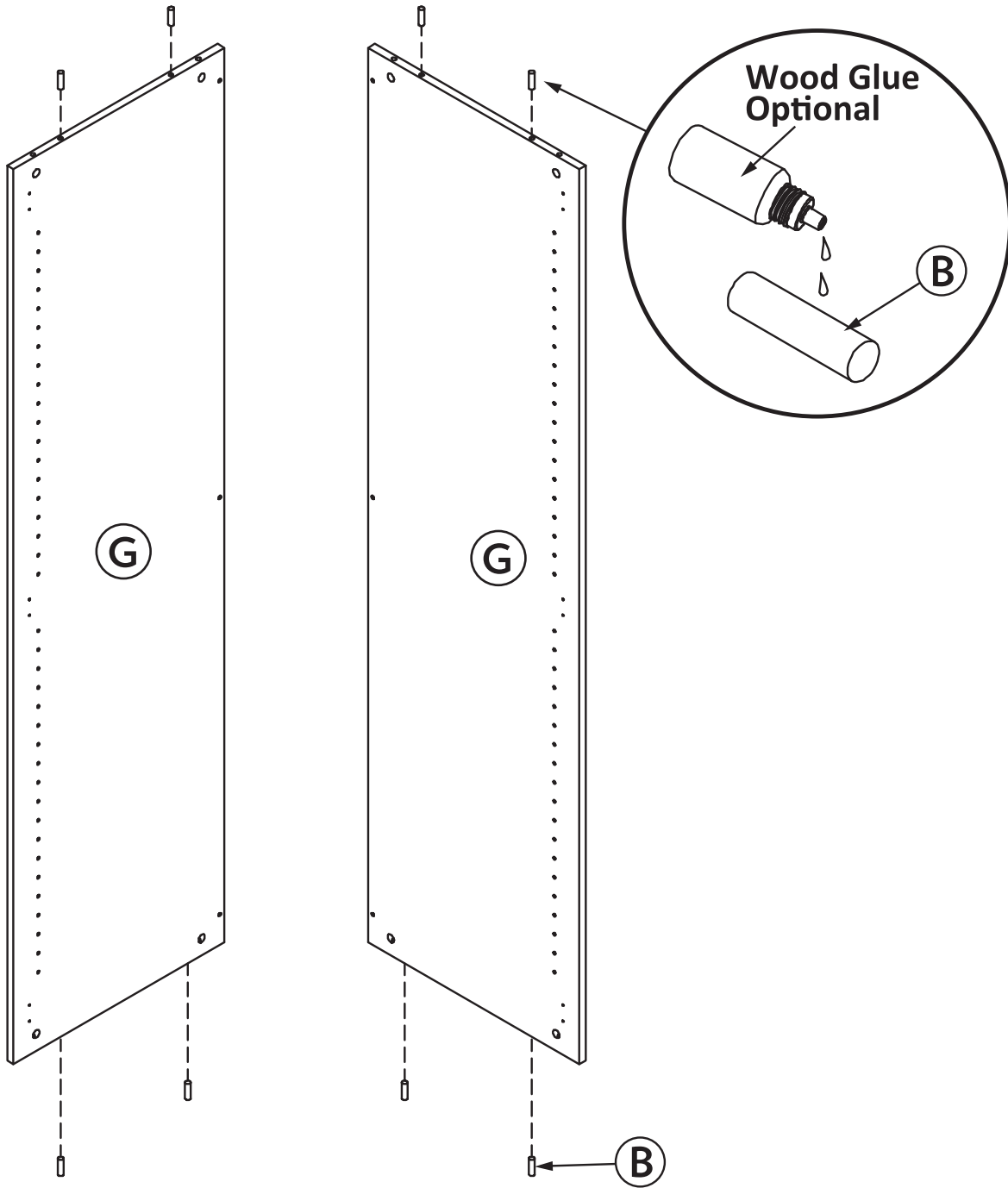

**Step 3.**

**Connect Panels-** Connect the top and bottom panels (F) to the side panels (G). Insert cams (A) into the holes on the sides. Slide the top and bottom together. Tighten the cams.

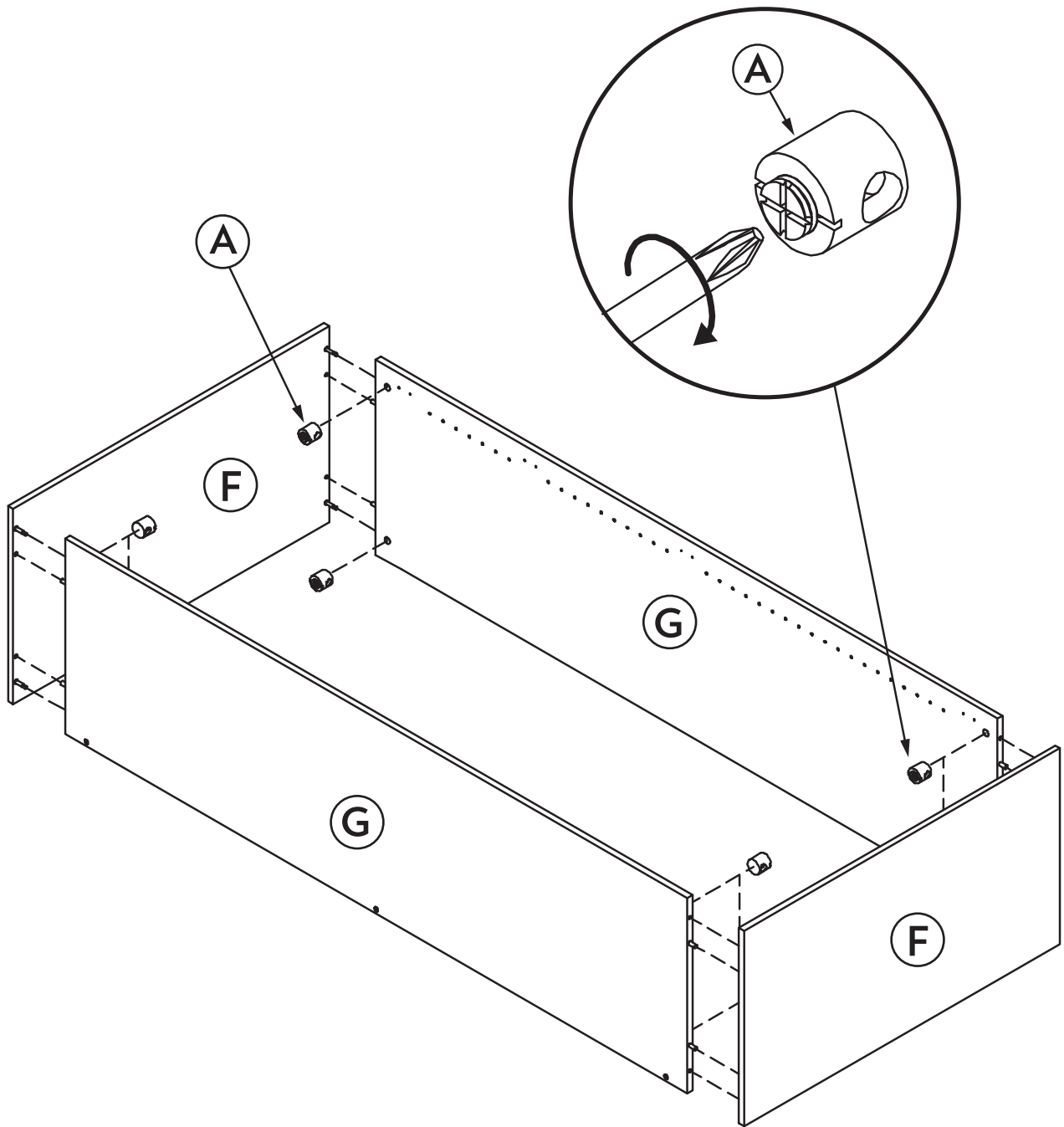

**Step 4.**

**Add Steel Spanners -** Assemble the steel spanners (C) to your cabinet using the spanner screws (D).

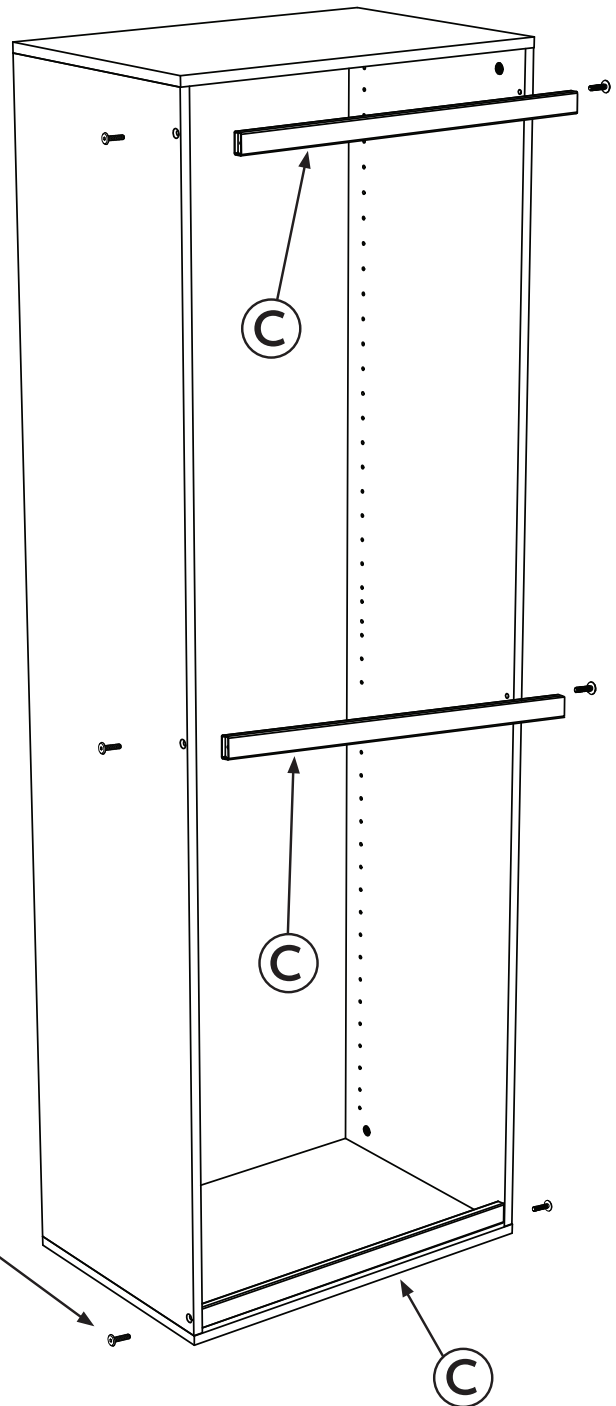
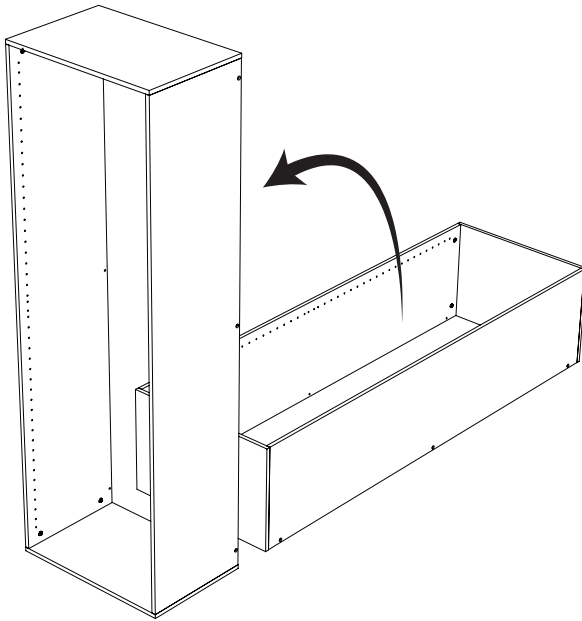

x6 (D)

**Step 5.**

**Hang the Cabinet** - Assemble the spanner brackets (E) to your Flow Wall panel wherever you would like to hang your cabinet. Hang the cabinet on the spanner brackets (E). After hanging, the cabinet can be adjusted side to side by sliding shell and brackets.

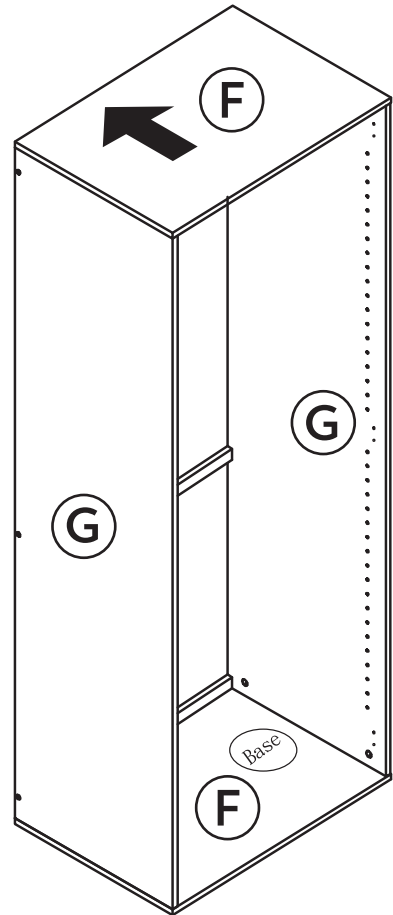
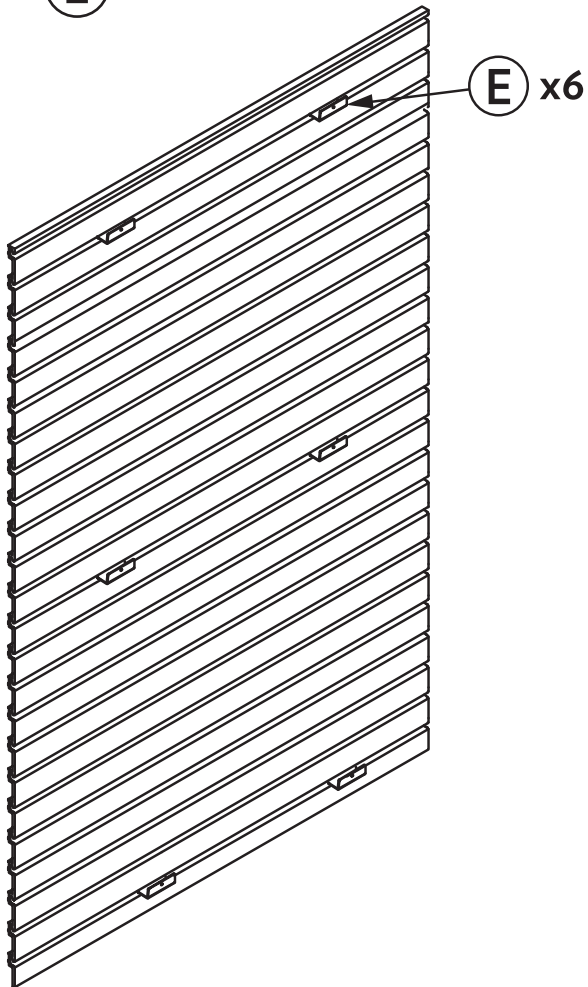
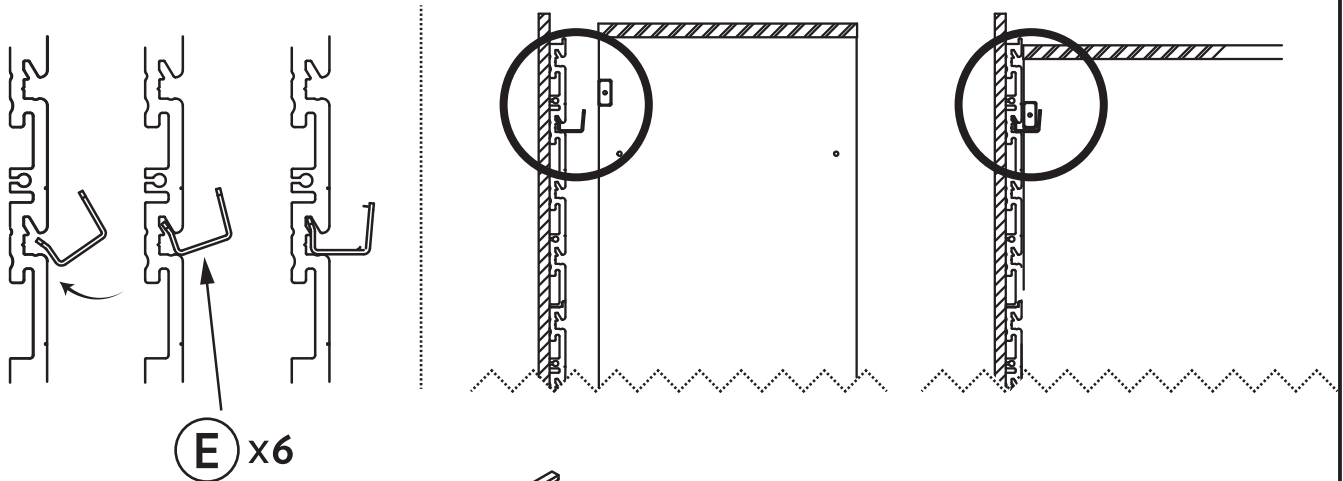

# STRUCTURE DU CABINET GRAND

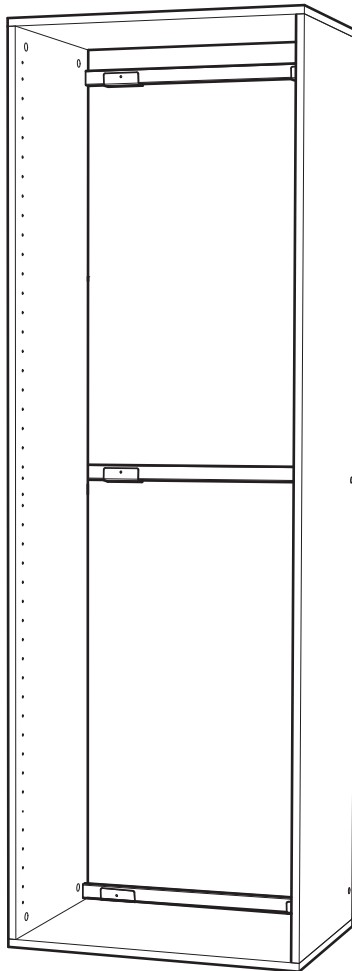



Modèle: **FWC-CAB1.2**

---



1891 W 2100 S  
Salt Lake City, UT 84119  
(877)-203-5974  
[customerservice@flowwall.com](mailto:customerservice@flowwall.com)

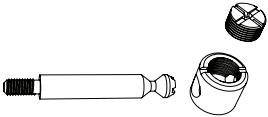

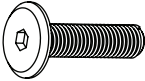
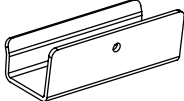
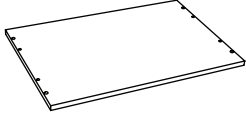
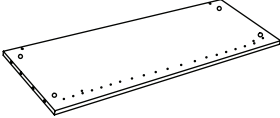
NO.	IMAGE	RÉFÉRENCE DESCRIPTION	QTE.
A		Came et Poteau	8
B		Cheville	8
C		Clé en acier	3
D		Clé à vis	6
E		Support de serrage	6
F		Dessus/Dessous du cabinet	2
G		Panneau latéral	2

**Étape 1.**

**Poteaux de montage** - Vissez le poteau (A) dans les orifices du receveur sur le panneau du dessus et du dessous (F).

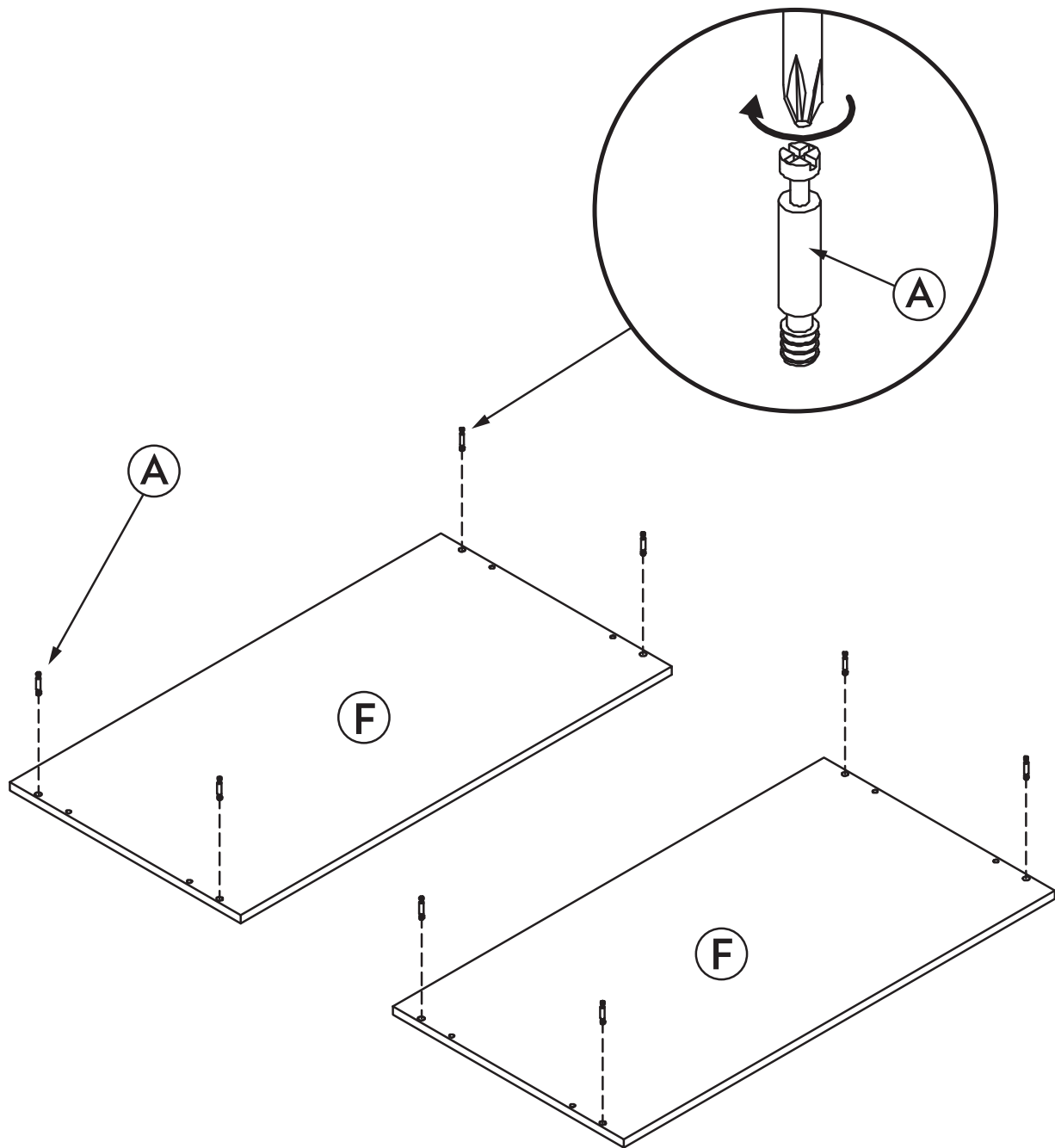

**Étape 2.**

**Panneau latéral -** Collez et insérez les chevilles (B) dans le panneau latéral (G).  
(colle à bois optionnelle)

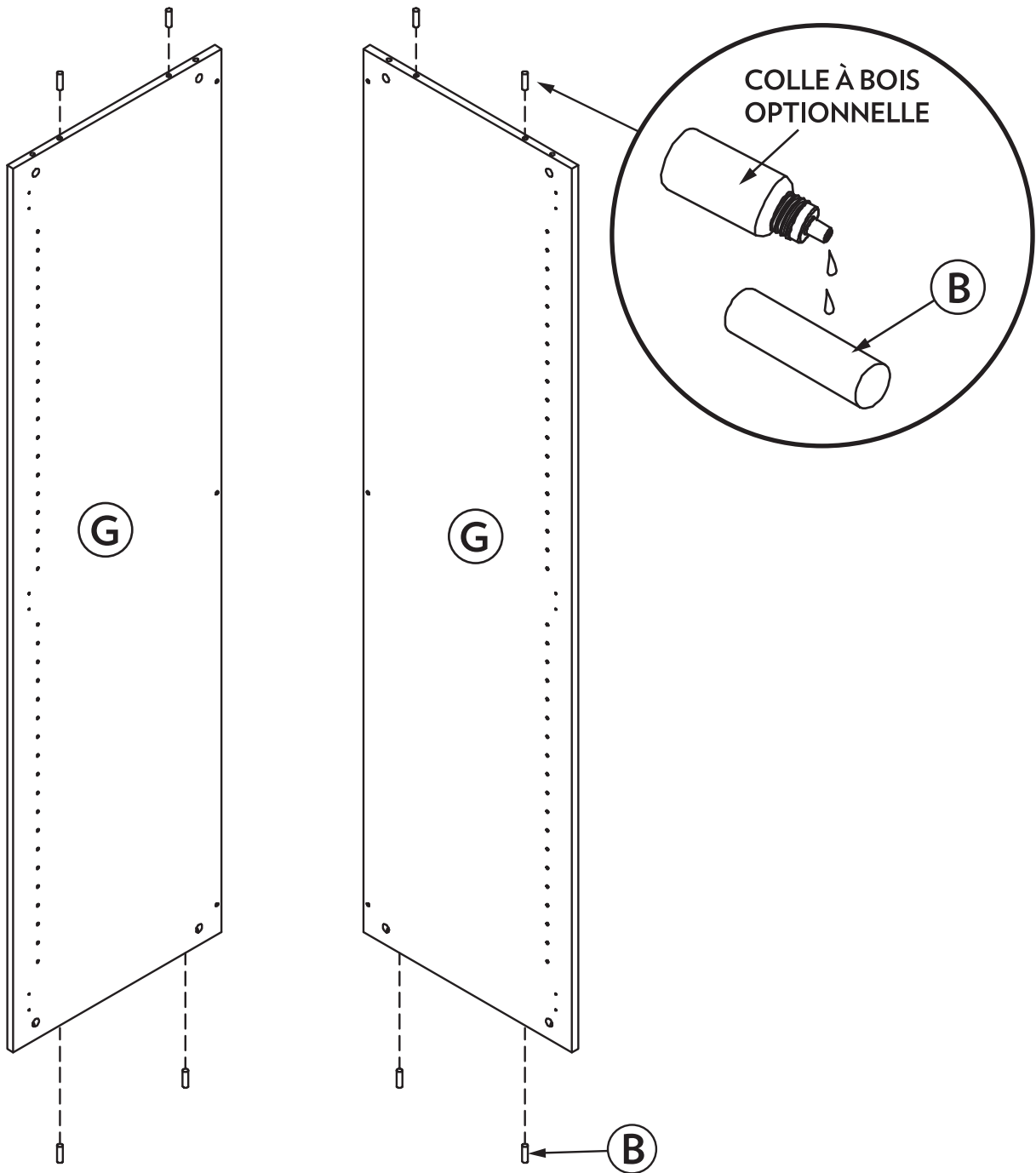

**Étape 3.**

**Connecter les Panneaux** - Connectez les panneaux du dessus et du dessous (F) aux panneaux latéraux (G). Insérez les cames (A) dans les orifices latéraux. Faites glisser la pièce du dessus et celle du dessous. Serrez les cames.

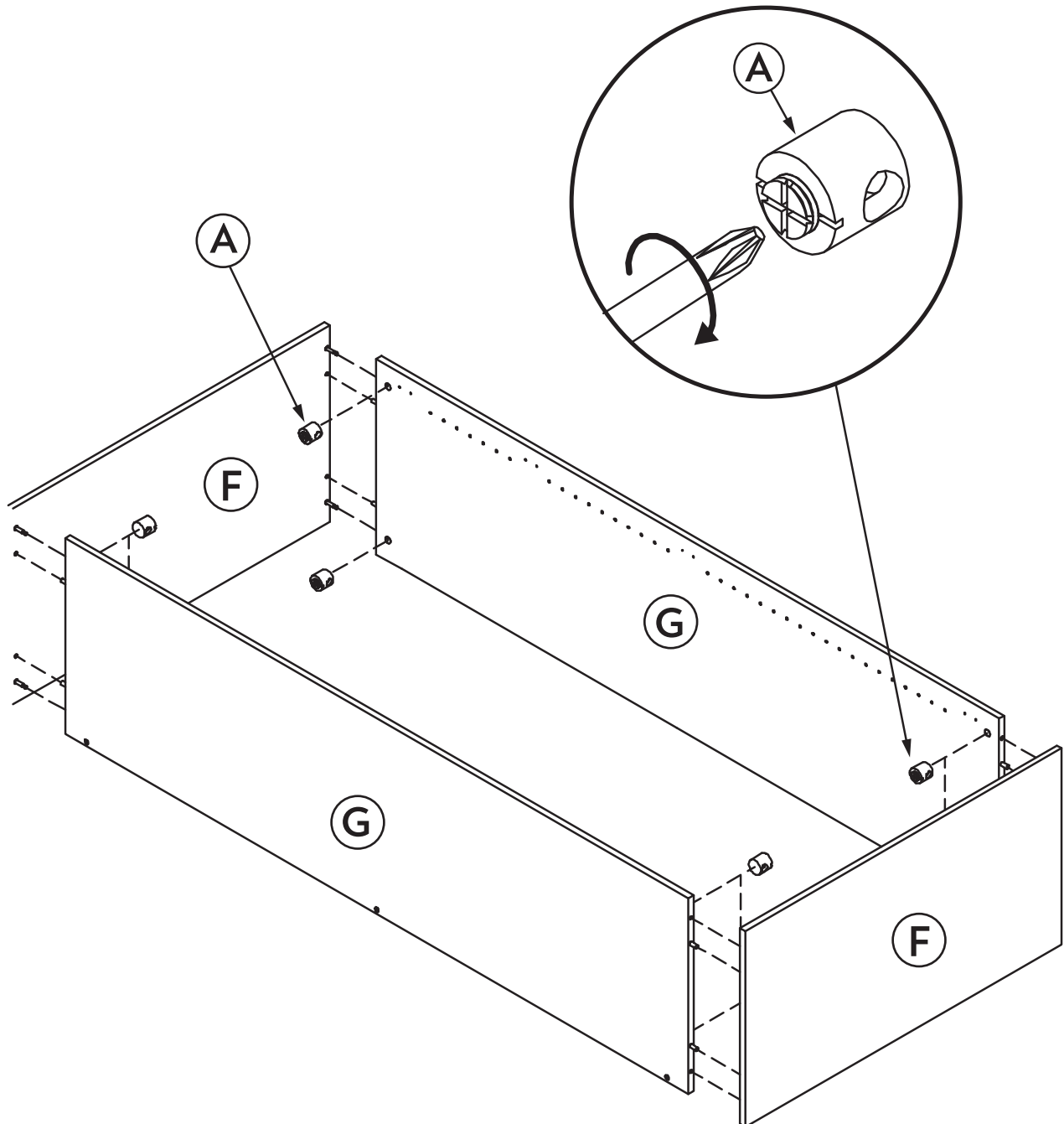

**Étape 4.**

**Support à étagère -** Assemblez les supports à étagère (C) à votre cabinet en utilisant les vis à étagère (D).

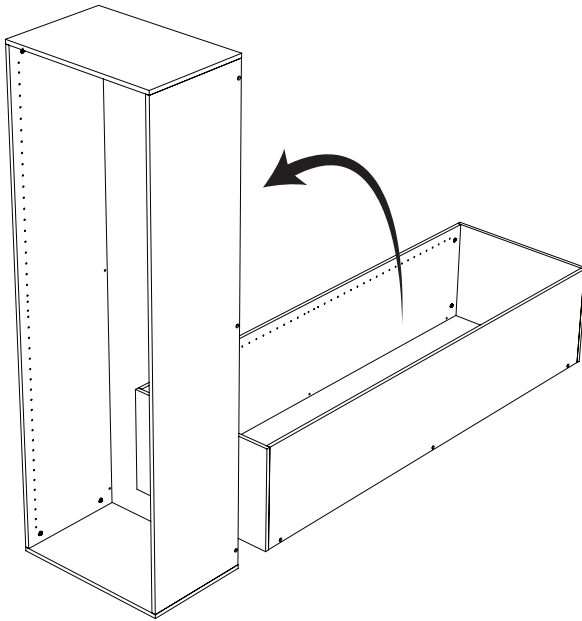

x6 (D)

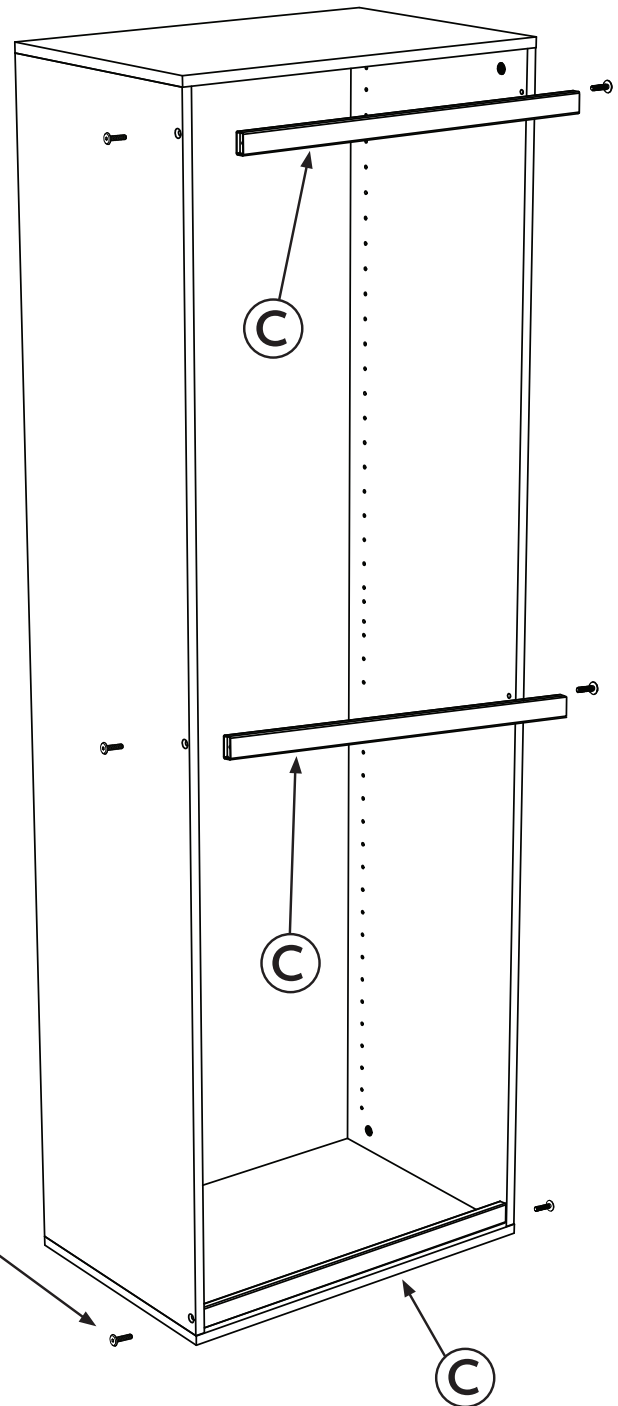

**Étape 5.**

**Suspension du cabinet -** Assemblez les supports à plateau (E) à votre plateau Flow Wall à l'endroit où vous souhaitez suspendre votre cabinet. Suspendez le cabinet aux supports à plateau (E). Après la suspension, le cabinet peut être ajusté côte à côte en glissant l'étagère et les plateaux.

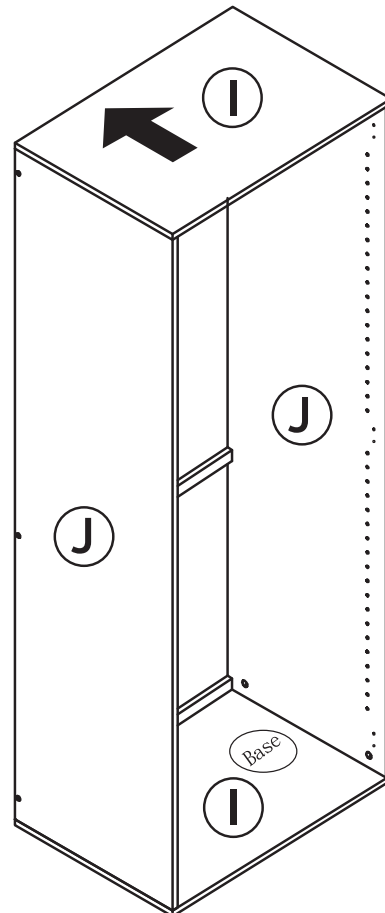
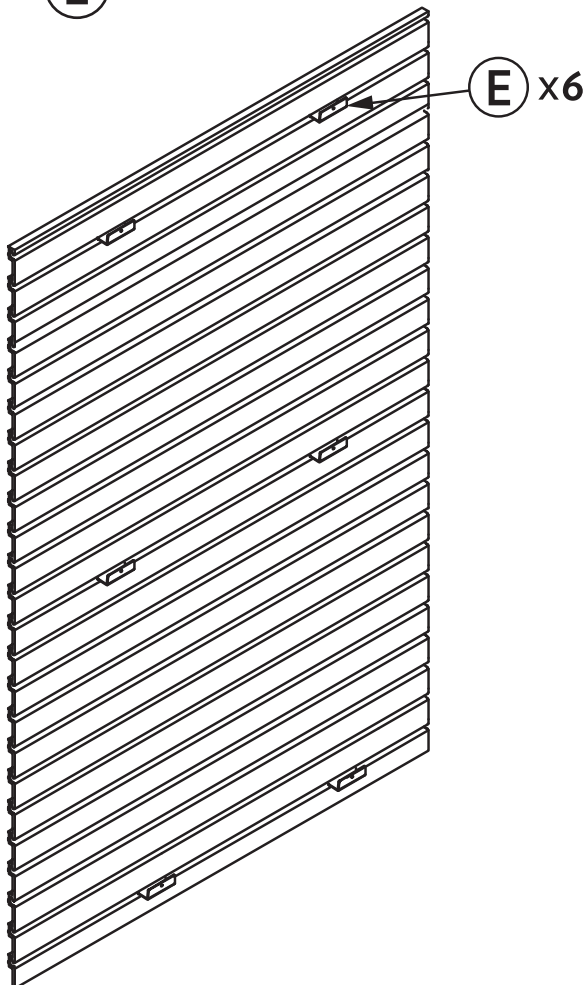
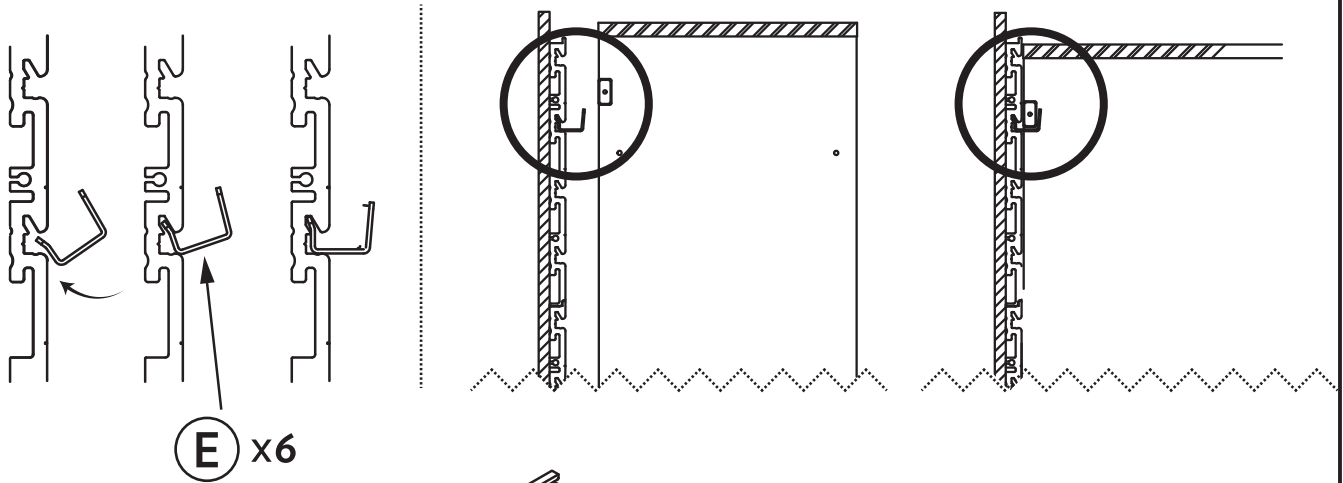

## ESTRUCTURAS DEL GABINETE ALTAS

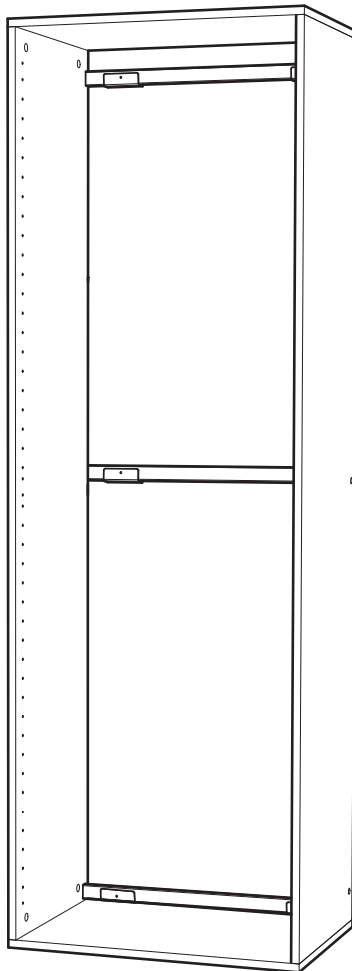



Modelo: **FWC-CAB1.2**

---

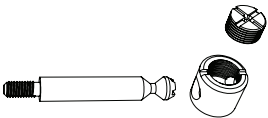

1891 W 2100 S  
Salt Lake City, UT 84119  
(877)-203-5974  
[customerservice@flowwall.com](mailto:customerservice@flowwall.com)

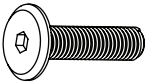
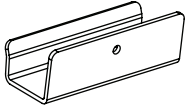
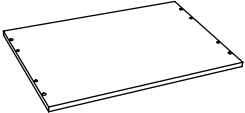
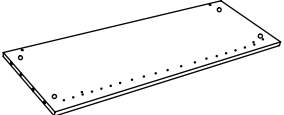
NO.	IMAGE	DESCRIPCIÓN (PARTE)	CANT.
A		Leva y perno	8
B		Tarugos	8
C		Llave de acero	3
D		Tornillo para llave	6
E		Soporte para llave	6
F		Panel superior e inferior del gabinete	2
G		Panel lateral	2



**Paso 1.**

Coloque los postes: Atornille los postes (A) en los orificios de recepción que se encuentran en la parte superior e inferior del panel (F).

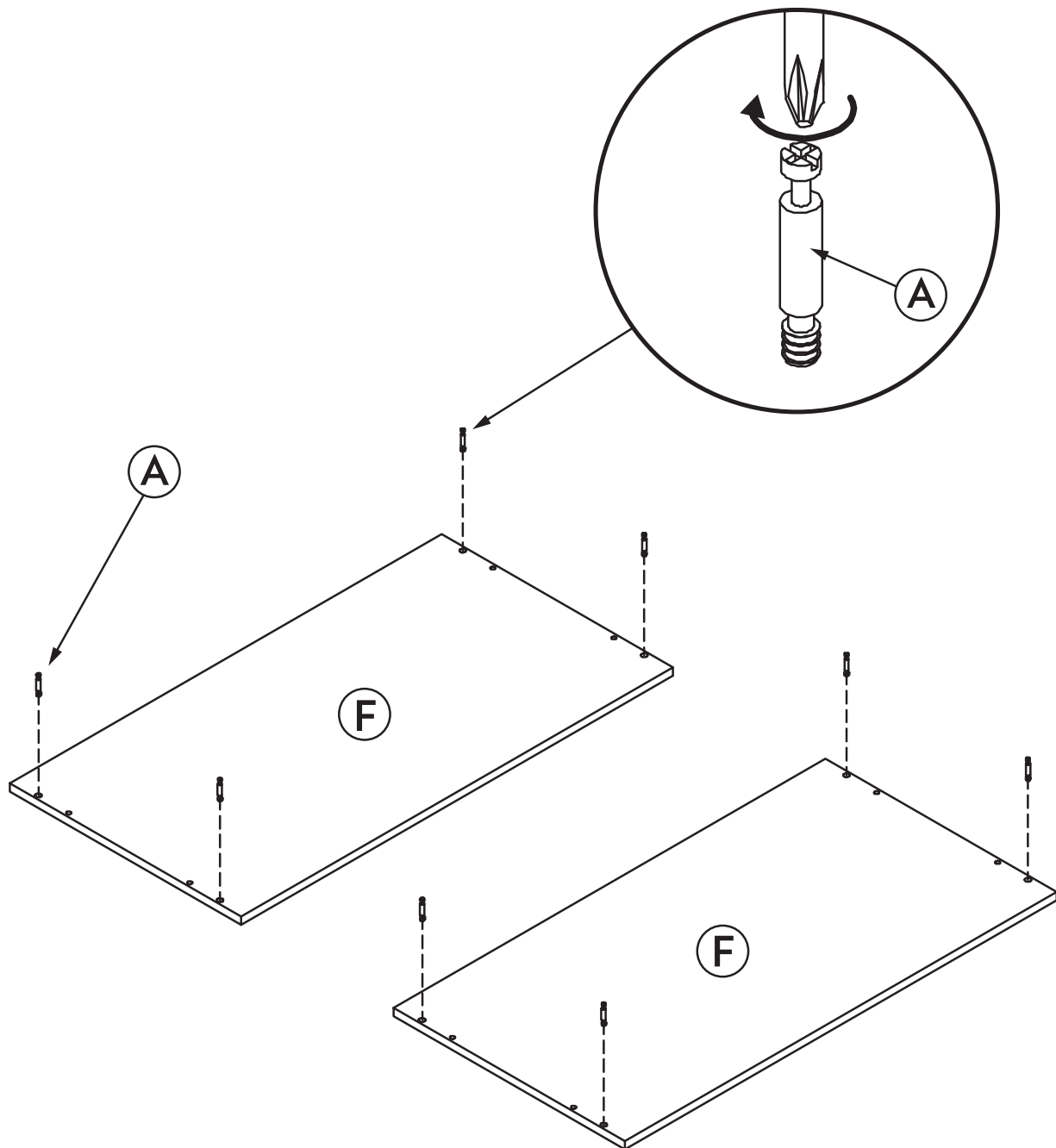

**Paso 2.**

**Panel lateral:** Pegue e inserte los tarugos (B) en el panel lateral (G).  
(el pegamento es opcional)

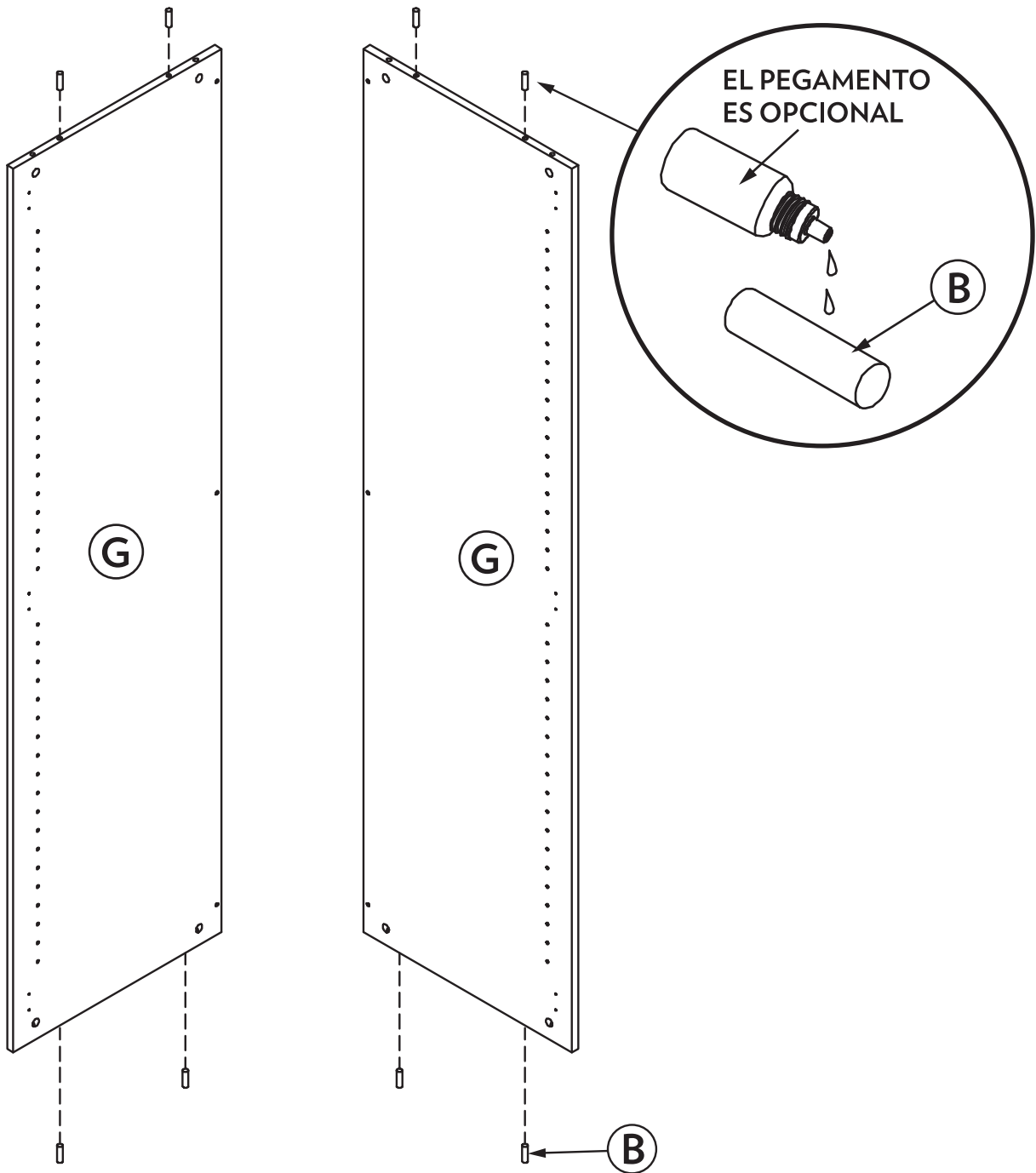

**Paso 3.**

**Conectar Paneles:** Una los paneles inferior y superior (G) a los paneles laterales (F). Inserte las levas (A) en los orificios de los laterales. Deslice, simultáneamente, los paneles superior e inferior. Ajuste las levas.

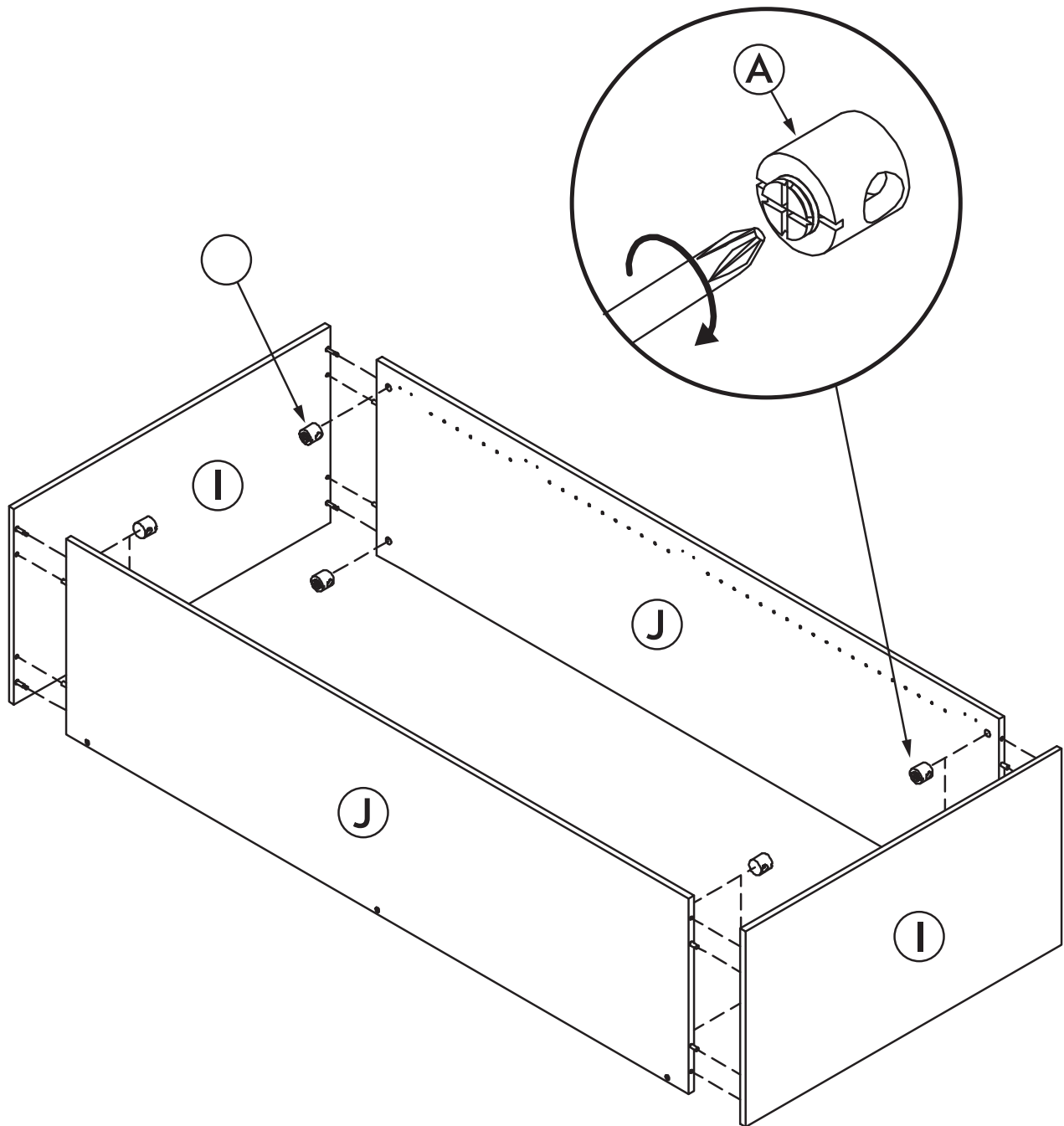

**Paso 4.**

**Llave de acero** - Ensamble los llaves de acero (C) en su gabinete utilizando los tornillos para llave (D).

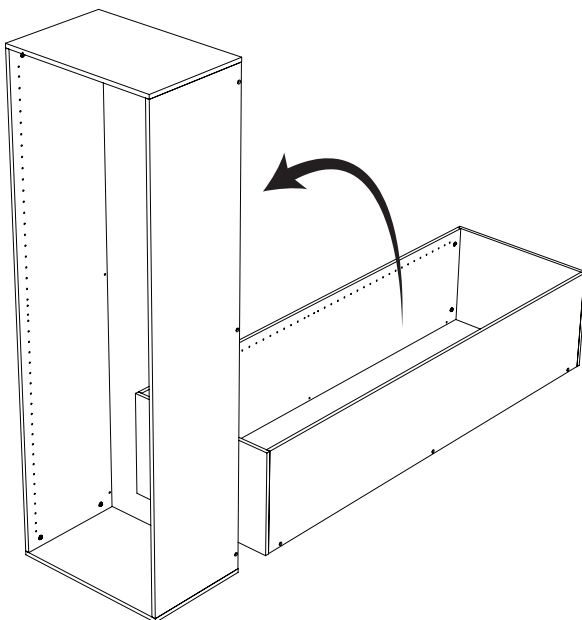

x6 (D)

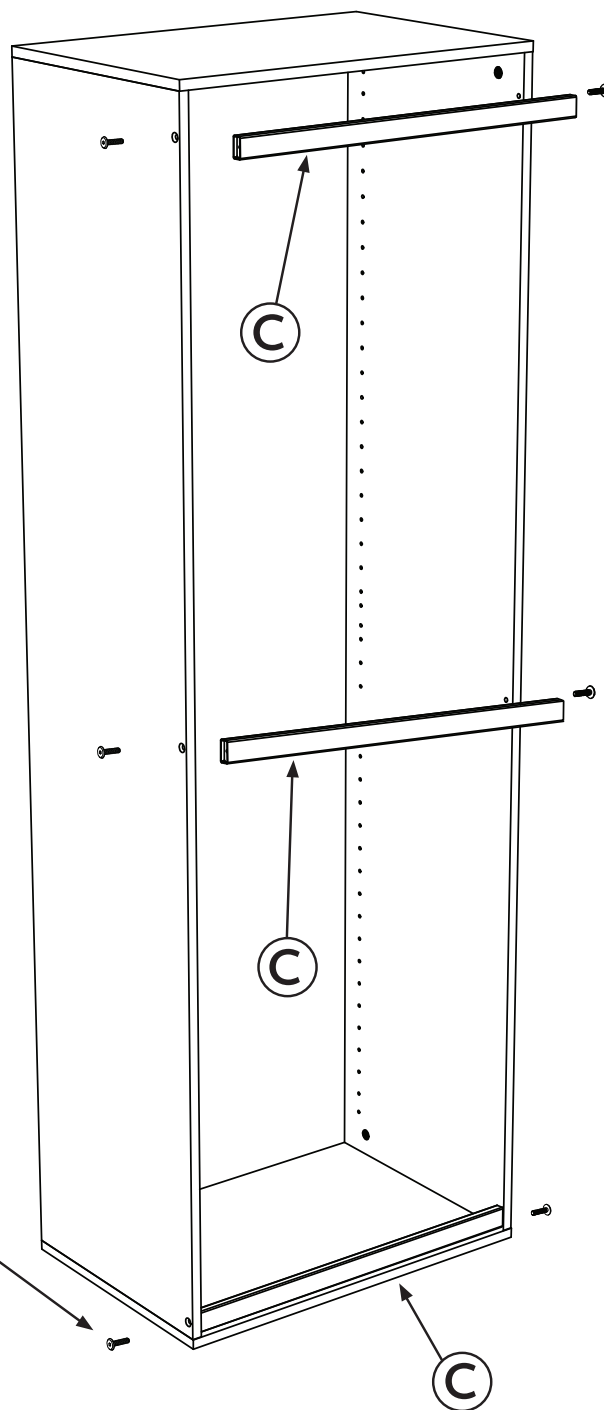

**Paso 5.**

**Cómo colgar el gabinete -** Ensamble los soportes para llave (E) en su panel Flow Wall en el lugar donde le gustaría colocar su gabinete. Cuelgue el gabinete en los soportes para llave (E). Una vez colgado, el gabinete puede ajustarse de lado a lado, deslizando la carcasa y los soportes.

